



Read this Owner's Manual thoroughly before operating the equipment. Keep it with the equipment at all times. Replacements are available from Thern, Inc.,

IMPORTANT: Please record product information on page 2. This information is required when calling the factory for service.



Owner's Manual

For
571 and 572 Series
Stationary Davit Cranes



Two-Year Limited Warranty

Please record the following:

Date Purchased: _____

Crane Model No.: _____

Crane Serial No.: _____

If sold with a winch:

Winch Model No.: _____

Winch Serial No.: _____

This information is required when calling the factory for service.

Thern, Inc. warrants its products against defects in material or workmanship for two years from the date of purchase by the original using buyer, or if this date cannot be established, the date the product was sold by Thern, Inc. to the dealer. To make a claim under this warranty, contact the factory for an RGA number. The product must be returned, prepaid, directly to Thern, Inc., 5712 Industrial Park Road, Winona, Minnesota 55987. The following information must accompany the product: the RGA number, the date of purchase, the description of the claimed defect, and a complete explanation of the circumstances involved. If the product is found to be defective, it will be repaired or replaced free of charge, and Thern, Inc. will reimburse the shipping cost within the contiguous USA.

This warranty does not cover any damage due to accident, misuse, abuse, or negligence. Any alteration, repair or modification of the product outside the Thern, Inc. factory shall void this warranty. This warranty does not cover any costs for removal of our product, downtime, or any other incidental or consequential costs or damages resulting from the claimed defects. This warranty does not cover brake discs, wire rope or other wear components, as their life is subject to use conditions which vary between applications.

FACTORY AUTHORIZED REPAIR OR REPLACEMENT AS PROVIDED UNDER THIS WARRANTY IS THE EXCLUSIVE REMEDY TO THE CONSUMER. THERN, INC. SHALL NOT BE LIABLE FOR ANY INCIDENTAL OR CONSEQUENTIAL DAMAGES FOR BREACH OF ANY EXPRESS OR IMPLIED WARRANTY ON THIS PRODUCT. EXCEPT TO THE EXTENT PROHIBITED BY APPLICABLE LAW, ANY IMPLIED WARRANTY OF MERCHANTABILITY OR FITNESS FOR A PARTICULAR PURPOSE ON THIS PRODUCT IS LIMITED IN DURATION TO THE DURATION OF THIS WARRANTY.

Some states do not allow the exclusion or limitation of incidental or consequential damages, or allow limitations on how long an implied warranty lasts, so the above limitation or exclusion may not apply to you. This warranty gives you specific legal rights, and you may also have other rights which vary from state to state.

Note: Thern, Inc. reserves the right to change the design or discontinue the production of any product without prior notice.

About This Manual

The Occupational Safety and Health Act of 1970 states that it is the employer's responsibility to provide a workplace free of hazard. To this end, all equipment should be installed, operated, and maintained in compliance with applicable trade, industrial, federal, state, and local regulations. It is the equipment owner's responsibility to obtain copies of these regulations and to determine the suitability of the equipment to its intended use.

This Owner's Manual, and warning labels attached to the equipment, are to serve as guidelines for hazard-free installation, operation, and maintenance. They should not be understood to prepare you for every possible situation.

The information contained in this manual is applicable only to the Thern 571 and 572 Series Stationary Davit Cranes. Do not use this manual as a source of information for any other equipment.

The following symbols are used for emphasis throughout this manual:

▲WARNING

Failure to follow 'WARNING!' instructions may result in equipment damage, property damage, and/or serious personal injury.

▲CAUTION

Failure to follow 'CAUTION!' instructions may result in equipment damage, property damage, and/or minor personal injury.

Important!

Failure to follow 'important!' instructions may result in poor performance of the equipment.



Suggestions for Safe Operation

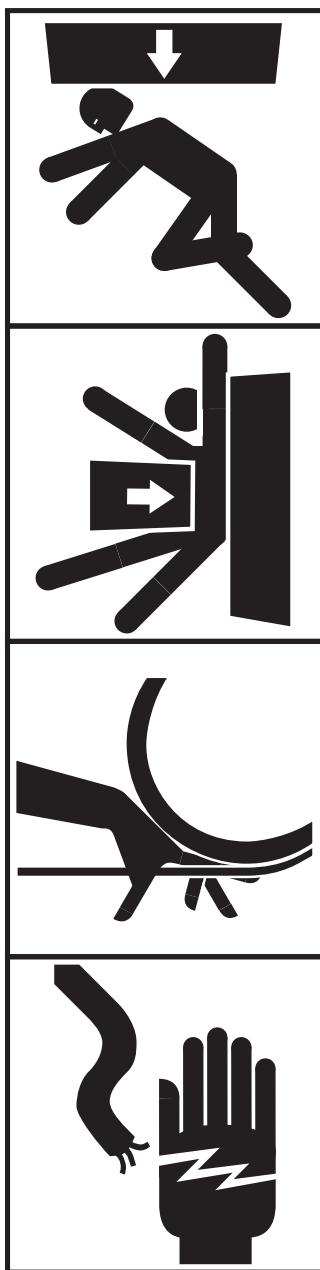

⚠ WARNING

DO the following:

Read and comply with the guidelines set forth in this Owner's Manual. Keep this manual, and all labels attached to the crane, readable and with the equipment at all times. Contact Thern, Inc. for replacements.

Check lubrication before use.

Install the wire rope securely to the winch drum.

Keep at least 4 wraps of wire rope wound on the drum at all times, to serve as anchor wraps. With less than 4 wraps on the drum the wire rope could come loose, causing the load to escape.

Keep hands away from sheaves, gears, wire rope, and other moving parts of the equipment.

Disconnect the power before servicing the equipment.

Keep all unnecessary personnel away from the crane while in operation. Keep out of the path of the load, and out of the path of a broken wire rope that might snap back and cause injury.

DO NOT do the following:

Do not lift people, or things over people. Do not walk or work under a load or in the line of force of any load.

Do not exceed the load rating of the crane or any other component in the system. To do so could result in failure of the equipment.

Do not use more than one crane to move a load that exceeds the load rating of a single crane. A shift in load weight could overload the equipment.

Do not use damaged or malfunctioning equipment. To do so could result in failure of the equipment.

Do not modify the equipment in any way. To do so could cause equipment failure.

Do not wrap the wire rope around the load. This damages the wire rope and could cause the load to escape. Use a sling or other approved lifting device.

Do not operate the crane with guards removed or improperly installed.

Do not divert your attention from the operation. Stay alert to the possibility of accidents, and try to prevent them from happening.

Do not jerk or swing the load. Avoid shock loads by starting and stopping the load smoothly. Shock loads overload the equipment and may cause damage.

Do not remove the winch or other components from the crane, and do not use these components for any use other than for their original intended function.

Do not use the crane to drag or pull loads. This will create side pulls which could damage the equipment or cause the load to tip.

Do not leave a suspended load unattended. Place the load on the ground if it must be left unattended.

Do not adjust the winch brake with the load suspended.

1.1 Installing the Crane

Important!

- A qualified professional should inspect or design the foundation to insure that it will provide adequate support.
- Locate the crane so it will be visible during the entire operation.
- Do not weld the crane base to the foundation or support structure. Welding the crane base may void warranty contact Thern, Inc. Use fasteners as instructed.

⚠WARNING

Do not install the crane in an area defined as hazardous by the National Electric Code, unless installation in such an area has been thoroughly approved.

Do not install the crane near corrosive chemicals, flammable materials, explosives, or other elements that may damage the crane or injure the operator. Adequately protect the crane and the operator from such elements.

Position the crane so the operator can stand clear of the load, and out of the path of a broken wire rope that could snap back and cause injury.

Attach the crane to a rigid and level foundation that will support the crane and its load under all load conditions, including shock loading.

- 1.1.1 CONSULT APPLICABLE CODES AND REGULATIONS for specific rules on installing the equipment.
- 1.1.2 LOCATE THE CRANE in an area clear of traffic and obstacles that could interfere with operation. Make sure the crane is accessible for maintenance and operation.
- 1.1.3 INSTALL THE CRANE on a level surface. **An unlevel surface may cause the boom to rotate in the direction the mast is leaning.**
- 1.1.4 FASTEN THE BASE securely to the foundation.
 - a FOR STANDARD PRODUCTS referred to in this manual, use 1/2-inch coarse thread fasteners, grade 5 or better torqued dry to 75 ft-lbs without lubrication for 571 series. Use 3/4-inch coarse thread fasteners, grade 5 or better torqued dry to 260 ft-lbs without lubrication for 572 series. Make sure the mounting holes are secured to a solid foundation able to support the crane and the load under all conditions with design factors based on accepted engineering practices.
 - b NON-STANDARD PRODUCTS that vary from the original design may have different fastening requirements. Contact a structural engineer or Thern, Inc for this information.

TO COMPLY WITH LOCAL CODES, CONTACT A QUALIFIED PROFESSIONAL TO OBTAIN PROPER STRUCTURE OR FOUNDATION SPECIFICATIONS FOR THE MOUNTING OF THERN PRODUCTS.

Table 1 – Crane Reactions

Crane Model	Mast Moment	Suggested Bolt Size	Axial Force ¹ Per Bolt
571	117,700 in-lbs	1/2 inch	5,200 lbs
572	204,100 in-lbs	3/4 inch	7,300 lbs

¹ Force in tension

1.2 Assembling the Crane

Important!

- Inspect the crane during assembly according to the Instructions for Periodic Inspection. This will give you a record of the condition of the crane with which to compare future inspections.
- Save all boxes and crates that the crane was shipped in, use them again if you need to repackage the crane.
- Contact the factory immediately if any parts are missing or damaged.
- Do not overtighten fasteners, this may strip threads or cause damage to other parts.

Figure 1 – Cotter Pins

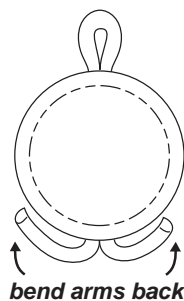

⚠CAUTION

When installing the boom brace or ratchet jack, support the end of the boom so the boom does not escape causing damage or injury

- 1.2.1 STUDY PARTS DRAWINGS to understand how the crane is assembled.
- 1.2.2 INSTALL THE BASE then assemble the crane in the following order.
- 1.2.3 LUBRICATE THE ENTIRE CRANE as you assemble it. Refer to the Lubrication Instructions.
- 1.2.4 FASTEN THE BOOM to the mast. **Make sure the boom is positioned correctly with the boom brace ears pointing down.**
 - a TIGHTEN THE CRANE LOCK to secure the mast and prevent it from rotating during assembly.
 - b FASTEN THE WINCH MOUNTING END OF THE BOOM to the mast using the boom pin and cotter pins provided.
 - c ON HAND OPERATED MODELS, install the sheave, cable keeper, and spacers on the boom pin as you fasten the boom to the mast.
- 1.2.5 INSTALL THE BOOM BRACE or ratchet jack.
 - a FASTEN ONE END OF THE BOOM BRACE or ratchet jack to the brace ears on the boom using the pin and cotter pins provided.
 - b RAISE THE BOOM and fasten the other end of the boom brace or ratchet jack to the brace ears on the mast using the pin and cotter pins provided.
- 1.2.6 FASTEN THE WINCH to the appropriate mounting plate, using the fasteners provided. On some models you will need to use the winch adapter plate and fasteners provided to fasten the winch to the crane. **Make sure the winch is positioned correctly. See page 16 and 17.**
- 1.2.7 INSTALL THE WINCH HANDLE on hand winches, or connect electric current on power winches. Refer to instructions in the Winch Owner's Manual.
- 1.2.8 INSTALL THE WIRE ROPE.
 - a REMOVE THE QUICK RELEASE PINS from both cable keepers.
 - b PASS THE WIRE ROPE through the cable keeper and over the sheave at the end of the boom.
 - c ON HAND OPERATED MODELS, pass the wire rope through the cable keeper and over the second sheave at the winch mounting end of the boom. **Make sure the wire rope passes through the slot in the boom and does not rub against the boom at any point.**
 - d RE-INSTALL BOTH QUICK RELEASE PINS.
 - e ANCHOR THE WIRE ROPE to the winch drum and wind 4 wraps of wire rope onto the drum to act as anchor wraps. Refer to the instructions in the Winch Owner's Manual.
- 1.2.9 MAKE SURE ALL FASTENERS are tightened, and cotter pins properly bent to secure them in place. See Figure 1.

2.1 General Theory of Operation

Important!

- Limit nonuniform winding by keeping tension on the wire rope.
- It is your responsibility to detect and account for different factors affecting the condition and performance of the equipment.

- 2.1.1 THE FORCE REQUIRED to move the load must not exceed the load rating of the crane. Consider the total force required to move the load, not the weight of the load.
- 2.1.2 THIS EQUIPMENT CAN develop forces that will exceed the load rating. It is the responsibility of the equipment user to limit the size of the load. Inspect the equipment regularly for damage according to the instructions contained in this manual.
- 2.1.3 PERFORMANCE RATINGS of the equipment are affected by the position of the boom, and the amount of wire rope you use. See the Performance Characteristics Tables on page 19.
- a LOAD RATING represents the maximum pull that can be placed on new equipment. Load ratings are assigned values for specific boom positions and wire rope lengths. **On Models equipped with a ratchet jack, the load rating decreases as you lower the boom.**
 - b LIFT varies with the position of the boom and the length of the wire rope.
 - c REACH varies with the position of the boom.
- 2.1.4 DUTY RATINGS refer to the type of use the equipment is subject to. Consider the following when determining duty rating.
- a ENVIRONMENT: harsh environments include hot, cold, dirty, wet, corrosive, or explosive surroundings. **Protect the equipment from harsh environments when possible.**
 - b MAINTENANCE: poor maintenance, meaning poor cleaning, lubrication, or inspection, leads to poor operation and possible damage of the equipment. **Minimize poor maintenance by carefully following the instructions contained in this manual.**
 - c LOADING: severe loading includes shock loading and moving loads that exceed the load rating of the equipment. **Avoid shock loads, and do not exceed the load rating of the equipment.**
 - d FREQUENCY OF OPERATION: frequent or lengthy operations increase wear and shorten the life span of gears, bearings, sheaves, and other components. **Increase maintenance of the equipment if used in frequent operations.**

CONTACT THE FACTORY FOR MORE INFORMATION.

2.2 Preparing for Operation

Important!

- When determining whether the load will exceed the load rating, consider the total force required to move the load.

⚠WARNING

When positioning the boom, avoid side pulls which could damage the crane or cause the load to tip.

When operating the ratchet jack, do not position the boom below horizontal. The load rating decreases as you lower the boom.

When operating the ratchet jack, do not raise the boom at an angle greater than 45-degree and do not force the ratchet handle pass the travel limits. To do so could cause the boom to fall resulting in damage or injury. See Figure 2.

- 2.2.1 CONSIDER THE OPERATION. Do not begin until you are sure you can perform the entire operation without hazard.
- 2.2.2 INSPECT ALL COMPONENTS of the system.
 - a INSPECT THE CRANE and other equipment according to the Instructions for Frequent Inspection.
 - b INSPECT THE WINCH according to the instructions in the Winch Owner's Manual.
 - c OPERATORS must be in good health, alert, thoroughly trained in operating the equipment, and properly clothed (hard hat, safety shoes and safety glasses, no loose clothing).
 - d THE LOAD must be clear of other objects and free to move. Make sure the load will not tip, spin, roll away, or in any way move uncontrollably.
- 2.2.3 KNOW YOUR LOAD and make sure you do not exceed the load rating of the crane or any other equipment in the system.
- 2.2.4 POSITION THE BOOM so the load hook is centered over the load. See Figure 3.
- 2.2.5 ON MODELS EQUIPPED WITH A RATCHET JACK, adjust boom height and reach by operating the ratchet jack.

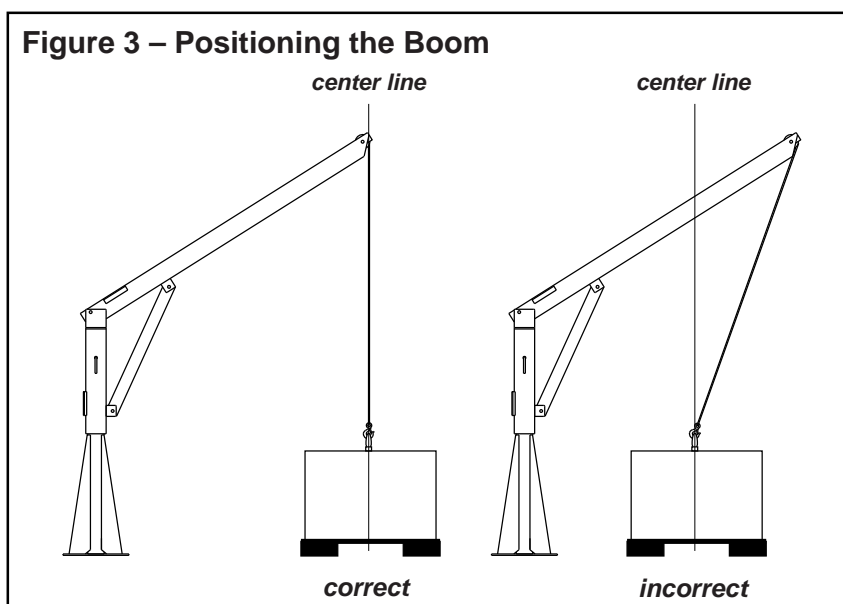
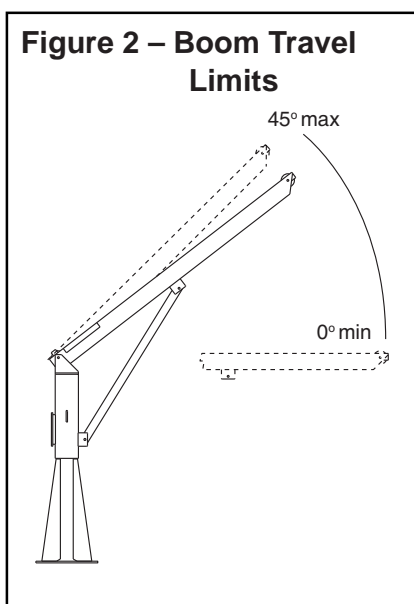

2.3 Attaching the Load

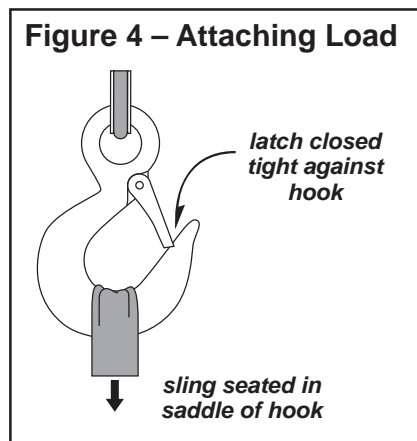

⚠WARNING

Do not wrap the wire rope around the load. This damages the wire rope and could cause the load to escape. Use a sling or other approved lifting device.

- 2.3.1 CLEAR OBJECTS from the path of the load so you can move it freely and observe it at all times during the operation.
- 2.3.2 MAKE SURE THE WIRE ROPE is not twisted. A twisted wire rope could cause the load to spin when it is raised off the ground.
- 2.3.3 ATTACH THE LOAD using a nylon sling, or other approved lifting device. Follow the recommendations of the sling manufacturer.
 - a SEAT THE SLING in the saddle of the hook with the hook latch completely closed. See Figure 4.
 - b CENTER THE LOAD on the hook so it will remain balanced and not tip or rotate to one side.

2.4 Moving the Load

Important!

- Obey a stop signal from anyone.
- Maintain tension on the wire rope to keep it tightly and evenly wound on the drum.
- If the crane and load are not visible during the entire operation, get help from another person.
- Appoint a supervisor if more than one person is involved in the operation. This will reduce confusion and increase safety.
- When lifting a load, use a tag line to keep the load from swinging or twisting, while keeping yourself away from the load.

⚠WARNING

When operating the ratchet jack, do not raise the boom at an angle greater than 45-degree and do not force the ratchet handle pass the travel limits. To do so could cause the boom to fall resulting in damage or injury. See Figure 2.

- 2.4.1 MOVE THE LOAD slowly and smoothly, only a small distance at first. Make sure the load is balanced and securely attached before continuing.
- 2.4.2 OPERATE THE WINCH to raise or lower the load. Refer to the instructions in the Winch Owner's Manual.
- 2.4.3 OBSERVE THE WIRE ROPE as it winds onto the drum. If it becomes loose, uneven, or overlapped, stop the operation and rewind the wire rope before continuing. **Continued operation with overlapped or uneven wire rope can damage the wire rope and shorten its life.**
- 2.4.4 ROTATE THE BOOM to move the load side-to-side.
 - a ROTATE THE BOOM slowly and smoothly to avoid swinging the load or causing shock loads. **Do not jam the boom against other objects.**
 - b USE THE HANDLE to rotate the boom. **Do not push or pull the load or the wire rope to rotate the boom.**

3.1 Cleaning the Crane

Important!

Increase the frequency of maintenance procedures if the crane is:

- Operated for long periods.
- Used to lift heavy loads.
- Operated in wet, dirty, hot, or cold surroundings.

Clean the crane to remove dirt and help prevent rust and corrosion.

- 3.1.1 CLEAN THE CRANE every six months or whenever it is dirty.
 - a WIPE ALL EQUIPMENT to remove dirt and grease.
 - b LEAVE A LIGHT FILM of oil on all surfaces to protect against rust and corrosion.
 - c WIPE OFF excessive amounts of oil to avoid the accumulation of dirt.
- 3.1.2 REMOVE UNNECESSARY OBJECTS from the area surrounding the crane.

3.2 Lubricating the Crane

Important!

- Make sure lubricant has a temperature rating appropriate for the ambient temperatures of the operation.

Lubricate the crane properly to help protect it from wear and rust. Read the following instructions carefully.

- 3.2.1 LUBRICATE ALL PINS at least every 3 months. Use a grease brush to apply a light film of NLGI #2 grease to all pins.
- 3.2.2 LUBRICATE THE ROLLERS at least every 3 months. Use a grease gun to apply an NLGI #2 grease to the grease fitting on each side of the mast until excess grease can be seen.
- 3.2.3 LUBRICATE THE MAST ROLLER BEARING at least every 3 months or whenever it squeaks or sounds dry when rotated. Use a grease gun to insert 5 to 10 pumps of an NLGI #2 grease to the grease fitting at the top of the mast.
- 3.2.4 LUBRICATE THE RATCHET JACK, if applicable, at least every 3 months. Use a grease gun to apply an NLGI #2 grease to the grease fittings on the ratchet jack until excess grease can be seen.
- 3.2.5 LUBRICATE THE WINCH at least every 3 months. Refer to the Winch Owner's Manual for instructions.
- 3.2.6 LUBRICATE THE WIRE ROPE and other equipment by following the manufacturers recommendation.

3.3 Inspecting the Equipment

Important!

- Start an inspection program as soon as you put the crane into use.
- Appoint a qualified person to be responsible for regularly inspecting the equipment.
- Keep written records of inspection. This allows comparison with comments from previous inspections so you can see changes in condition or performance.

Perform frequent inspections:

- Before each operation.
- Every 3 hours during operation.
- Whenever you notice signs of damage or poor operation.

Frequent Wire Rope Inspection:

- Use ASME B30.7 as a guideline for rope inspection, replacement and maintenance.
- Check the wire rope, end connections and end fittings for corrosion, kinking, bending, crushing, bird-caging or other signs of damage.
- Check the number, distribution and type of visible broken wires. See paragraph 3.3.4 b and Figure 5.
- Check the wire rope for reduction of rope diameter from loss of core support, or wear of outside wires. See Figure 7.
- Take extra care when inspecting sections of rapid deterioration such as sections in contact with saddles, sheaves, repetitive pickup points, crossover points and end connections.

▲WARNING

Do not use damaged or malfunctioning equipment. Place an “OUT OF ORDER” sign on the crane. Do not use the crane until the sign is removed by a qualified maintenance person who has completely corrected the problem.

Inspect the crane to detect signs of damage or poor operation before they become hazardous. See Table 2 - Inspection Checklist.

3.3.1 CONSULT APPLICABLE CODES AND REGULATIONS for specific rules on inspecting the crane and other equipment.

3.3.2 REFER TO THE WINCH OWNER'S MANUAL for information regarding winch inspection.

3.3.3 Instructions for Frequent Inspection

- a VISUALLY INSPECT the entire crane and all other equipment involved in the operation.
 - Check all equipment for cracks, dents, bending, rust, wear, corrosion and other damage.
 - Make sure the wire rope is installed correctly and anchored securely.
 - Make sure the entire crane is properly lubricated.
 - Make sure all fasteners are tight and secure.
 - Make sure mounting fasteners are tightened securely.
 - Check the ratchet jack, if applicable, for signs of leakage or damage, and make sure it operates smoothly to raise and lower the boom.
 - Make sure the foundation is in good condition, and capable of supporting the crane and its load under all load conditions.
- b TEST CRANE PERFORMANCE by operating the crane with a load not exceeding the load rating.
 - Listen for unusual noises, and look for signs of damage as you operate the crane.
 - Make sure the wire rope winds evenly and tightly onto the drum. If it is loose or uneven, rewind it before continuing.
 - Make sure the load moves smoothly, without hesitation or strain.
 - On hand operated models, make sure the winch handle rotates freely in both directions.
 - On power operated models, make sure the winch responds to the control device. It must rotate as shown on the control labels, and it must turn off when you release the control.
 - Make sure the boom rotates freely when you push the handle, and remains stationary when you release it.
 - Check the brake. Raise the load, then lower it and stop it a few feet off the ground. If the load continues to coast or creep, the brake may be worn and in need of repair or replacement. Contact the factory.

Completely correct all problems before continuing. Use the Troubleshooting Chart to help determine the cause of certain problems. See Table 4.

Table 2 – Inspection Checklist *checked boxes indicate damage or problem in need of repair*

	damages	problems
general	<input type="checkbox"/> finish weathered, flaking, otherwise damaged <input type="checkbox"/> parts cracked, bent, rusted, worn, otherwise damaged	<input type="checkbox"/> equipment not properly lubricated <input type="checkbox"/> unusual noises, other signs of malfunction
foundation	<input type="checkbox"/> loose, unstable, otherwise damaged	<input type="checkbox"/> not level - boom swerves
fasteners	<input type="checkbox"/> stripped threads, bent, worn, otherwise damaged	<input type="checkbox"/> loose, not tightened to the proper torque
boom assembly	<input type="checkbox"/> holes worn, distorted, or otherwise damaged	<input type="checkbox"/> does not rotate freely
winch assembly	<input type="checkbox"/> gears, bearings, and other parts worn, otherwise damaged <input type="checkbox"/> brake corroded, cracked, worn, otherwise damaged	<input type="checkbox"/> winch jerks or hesitates under load <input type="checkbox"/> brake does not operate properly
sheave	<input type="checkbox"/> holes worn, distorted, or otherwise damaged	<input type="checkbox"/> does not rotate freely
bearings	<input type="checkbox"/> corroded, worn, seized, or otherwise damaged	<input type="checkbox"/> not properly lubricated
wire rope	<input type="checkbox"/> bent, crushed, otherwise damaged <input type="checkbox"/> broken wires, see Figure 5 replace if more than 6 wires in one lay, or 3 wires in one strand in one lay, are broken <input type="checkbox"/> diameter reduced, see Figure 7 replace if diameter is excessively worn	<input type="checkbox"/> wire rope loosely or unevenly wound number per strand = _____ number per lay = _____ diameter = _____
end connections	<input type="checkbox"/> corroded, rusted, worn, otherwise damaged	<input type="checkbox"/> not securely attached
load hook	<input type="checkbox"/> twisted, bent, worn, otherwise damaged, see Figure 6 replace if twist is 10 degrees or more replace if throat width is 15% larger than nominal replace if thickness is 10% less than nominal	<input type="checkbox"/> hook latch fails to close when released twist = _____ throat width = _____ thickness = _____
labels and plates	<input type="checkbox"/> dirty, illegible, otherwise damaged	<input type="checkbox"/> loosely attached or missing

comments:

authorized signature: _____ date _____



Perform periodic inspections:

- Every 6 months.
- Whenever you return the crane to service from storage.
- Whenever you notice damage or poor operation in a frequent inspection.
- Whenever you have, or think you may have, overloaded or shock loaded the crane.

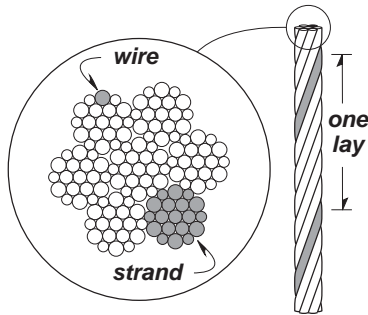
Figure 5 – Broken Wires

Wire rope assembly must be replaced if more than 6 wires are broken in one lay, or if more than 3 wires are broken in one strand in one lay.

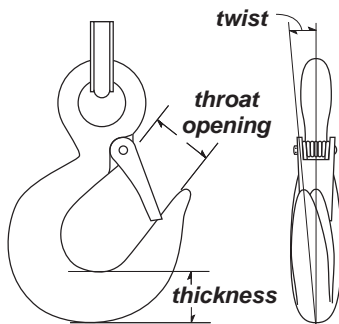
Figure 6 – Load Hook Inspection

The wire rope assembly must be replaced if the throat opening is 15% wider than nominal, if the thickness is 10% less than nominal, or if the hook is twisted 10° or more.

3.3.4 Instructions for Periodic Inspection.

- VISUALLY INSPECT** the crane and all other equipment.
 - Disassembly may be required in order to properly inspect individual components. Contact factory for assembly/disassembly instructions. **Disassembly of the winch or crane before contacting Thern, Inc. voids all warranties.**
 - Check the finish for wear, flaking, or other damage.
 - Check all equipment for cracks, dents, bending, rust, wear, corrosion and other damage. If the crane was overloaded, or if you notice cracks and other signs of overloading and damage, promptly remove equipment from use and have it repaired or replaced. **DO NOT CONTINUE TO USE DAMAGED OR OVERLOADED EQUIPMENT OR WIRE ROPE.**
 - Check all fasteners for stripped threads, wear, bending, and other damage.
 - Make sure the entire crane is properly lubricated.
 - Check the ratchet jack, if applicable, for signs of leakage or damage, and make sure it operates smoothly to raise and lower the boom.
 - Make sure all labels and plates are readable, firmly attached, free of damage and clean. Replacements are available from the factory.
- INSPECT THE WIRE ROPE** according the wire rope manufacturer's recommendations, or follow accepted industry standards for wire rope inspection.
 - Always wear protective clothing when handling wire rope.
 - Check the entire length of wire rope for bent wires, crushed areas, broken or cut wires, corrosion, and other damage. Carefully inspect areas that pass over sheaves or through roller guides.
 - Note the location and concentration of broken wires. Replace wire rope if more than 6 wires are broken in one lay, or more than 3 wires are broken in one strand in one lay. See Figure 5.
 - Make sure the load hook or other device is securely attached to the wire rope, and the wire rope where it is attached is not frayed, corroded, broken, or otherwise damaged.
 - Measure the throat opening, thickness, and twist of the hook. Replace the hook if it shows signs of damage. See Figure 6.
 - Make sure hook latch opens without binding and closes when released.
 - Check the anchor holes in the drum and the surrounding area for signs of wear or distortion.
- PLACE** enough weight to keep the wire rope straight and tightly drawn.
 - Measure the diameter of the wire rope, especially in areas where wear is noticeable. Replace the wire rope if the diameter measures below the minimum diameter at any point. See Figure 7.
- REMOVE THE WINCH** and inspect it by following the instructions in the Winch Owner's Manual.
- DISASSEMBLE THE CRANE** by removing the boom brace or ratchet jack, the boom, and the sheaves. Inspect each component for damage.
- REMOVE THE CRANE BASE** from the foundation.
 - Check fasteners for stripped threads, wear, bending, and other damage.
 - Check the foundation for cracks, corrosion, and other damage.

Figure 7 – Rope Diameter

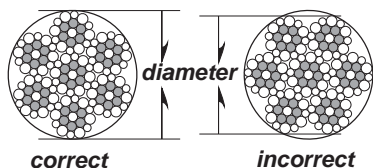

The wire rope assembly must be replaced if the diameter measures less than the minimum diameter at any point.

wire rope diameter	minimum diameter
3/16 in	11/64 in (.1719 in)
1/4 in	15/64 in (.2344 in)
5/16 in	19/64 in (.2969 in)
3/8 in	11/32 in (.3438 in)

- g FASTEN THE CRANE BASE securely to the foundation.
- h REASSEMBLE THE CRANE.
- i TEST CRANE PERFORMANCE by operating the crane with a load equal to the load rating.
 - Listen for unusual noises, and look for signs of damage as you operate.
 - Make sure the wire rope winds evenly and tightly onto the drum. If it is loose or uneven, rewind it before continuing.
 - Make sure the load moves smoothly, without hesitation or strain.
 - On hand operated models, make sure the winch handle rotates freely in both directions.
 - On power operated models, make sure the winch responds to the control device. It must rotate as shown on the control labels, and it must turn off when you release the control.
 - Make sure the boom rotates freely when you push the handle, and remains stationary when you release it.
 - Check the brake. Raise the load, then lower it and stop it a few feet off the ground. If the load continues to coast or creep under normal operating condition, the brake may need repair or replacement. Contact the factory.

Completely correct all problems before continuing. Use the Troubleshooting Chart to help determine the cause of certain problems. See Table 4.

Important!

- It is your responsibility to determine when to replace parts. When considering whether to continue using a part or to replace it, remember that replacing it is the best way to avoid further equipment damage.
- If repair or replacement of the mast, base, or bearings within should become necessary, please call the factory.
- Appoint a qualified person to be responsible for all repairs to the equipment.

3.4 Repairing the Crane

- 3.4.1 GET FACTORY AUTHORIZATION for all repairs. Unauthorized repairs will void the warranty, and may lead to damage or failure of the crane.
- 3.4.2 REPLACE DAMAGED OR POORLY OPERATING PARTS with Thern repair parts.
- 3.4.3 REFINISH AREAS where the paint is worn or flaking. A good finish helps to protect against corrosion and weather damage.
 - a REMOVE THE FINISH from damaged areas, down to the bare metal.
 - b CLEAN THE AREA thoroughly.
 - c REPAINT with a high quality primer and finishing coat.
- 3.4.4 TO ORDER REPAIR PARTS, contact your local dealer. Include the following information when ordering:
 - model number
 - **serial number** (or code number)
 - part number
 - date purchased, and from whom
 - description of what happened, or what is wrong
 - your name and return address

4.1 Transporting the Crane

Important!

- Keep a record of what you ship, and when you send it.

- 4.1.1 PARTIALLY DISASSEMBLE THE CRANE into components that can be transported.
- 4.1.2 PACK THE CRANE for transport, using the original packaging materials, if appropriate.
- 4.1.3 PACK THE WINCH in an upright position for transport, using the original packaging materials, if possible.
- 4.1.4 REASSEMBLE THE CRANE at its new location following the instructions under Section 1.2 Assembling the Crane.
- 4.1.5 INSPECT THE CRANE according to Section 3.3.3 Instructions for Frequent Inspection before installing it for operation.

4.2 Storing the Crane

- 4.2.1 PARTIALLY DISASSEMBLE THE CRANE and store all parts in a cool clean place away from corrosive chemicals and moisture.
- 4.2.2 SEAL THE CRANE in plastic with a desiccant to help protect it from rust, corrosion, and other damage.
- 4.2.3 SEAL THE WINCH in plastic with a desiccant to help protect it from rust, corrosion, and other damage.
- 4.2.4 REASSEMBLE THE CRANE at its new location following the instructions under Assembling the Crane.
- 4.2.5 INSPECT THE CRANE according to the Instructions for Section 3.3.4 Periodic Inspection before installing it for operation.
- 4.2.6 LUBRICATE THE CRANE PROPERLY prior to operation. See Section 3.2 Lubricating the Crane.

Model	Weight	
	LB	KG
M4312PB-K	26	11.79
M452B-K	78	35.38
4WM2V-K	37	16.78
4WP2-K	77	34.93
4777-K	80	36.29
4771-K	80	36.29
4WS3M6-K	272	123.40



Table 4 – Troubleshooting Chart

Contact the factory for detailed instructions if you are required to disassemble the crane or winch for any reason. Disassembly of the crane or winch before contacting Thern, Inc. voids all warranties.

problem	cause	correction
overheating	<ul style="list-style-type: none"> operated too long without rest. load too heavy poor lubrication. bearing seized up 	<ul style="list-style-type: none"> allow to cool lighten load inspect and lubricate as necessary inspect and replace as necessary
boom bounces up and down	<ul style="list-style-type: none"> load too heavy mounting bolts loose sheave worn or damaged. foundation loose or unlevel winch gears worn or damaged 	<ul style="list-style-type: none"> lighten load tighten mounting bolts to proper torque inspect and replace as necessary inspect and repair as necessary inspect and repair as necessary
boom does not rotate	<ul style="list-style-type: none"> rotation points contaminated or worn flange bearing broken or locked. 	<ul style="list-style-type: none"> inspect and repair as necessary inspect and replace as necessary
boom rotates on its own	<ul style="list-style-type: none"> foundation loose or unlevel mast bent, distorted, or leaning. 	<ul style="list-style-type: none"> inspect and repair as necessary inspect and repair as necessary
unusual noises		
high pitched squeak	<ul style="list-style-type: none"> poor lubrication. 	<ul style="list-style-type: none"> lubricate entire crane properly
grinding noise	<ul style="list-style-type: none"> contaminated lubricant at rotation points 	<ul style="list-style-type: none"> clean and lubricate rotation points
rattling noise	<ul style="list-style-type: none"> loose bolts, set screws or other fasteners 	<ul style="list-style-type: none"> tighten all bolts and other fasteners

Refer to the Winch Owner's Manual for possible problems with the winch and brake.

Table 5 – Crane Weight Chart

Model 571

Component	Part Numbers	Component Weight		Assembly/Disassembly Weight (with pins)	
		LB	KG	LB	KG
Mast	C3212	260	118.10	262	118.74
Boom	B3256	96	43.28	98	44.55
Boom Brace	B1533	14	6.28	14	6.28
Jack	C3213	35	15.88	35	15.88
Handle	B3292	4	1.59	4	1.59
	TOTAL	409	185.12	413	187.04

Model 572

Component	Part Numbers	Component Weight		Assembly/Disassembly Weight (with pins)	
		LB	KG	LB	KG
Mast	C3193	388	176.05	394	178.59
Boom	C3196	190	86.23	194	88.15
Boom Brace	B1498	32	14.28	32	14.28
Jack	C3235	101	45.55	101	45.55
Handle	B3292	4	1.59	4	1.59
	TOTAL	715	323.70	725	328.17



Stationary Davit Crane		571M1		572M1		571M2		571E2	
item	description	part number	qty.	part number	qty.	part number	qty.	part number	qty.
1	MAST SUBASSEMBLY	C3212	1	C3193	1	C3212	1	C3212	1
2 ¹	BOOM BRACE	B1533	1	B1498	1	B1533	1	B1533	1
3	BOOM SUBASSEMBLY	B3257	1	C3196	1	B3257	1	B3257	1
4	HAND WINCH	M4312PB-K	1	M452B-K	1	4WM2V-K	1	4WP2-K	1
5	CAPSCREW HEXHD	A2975	4	A3164	4	A3355	4	A3355	4
6	FLAT WASHER	—		A2932	8	—		—	
7	HEX NUT NYLK	A3231	4	A2897	4	A3356	4	A3356	4
8	SHEAVE ASSEMBLY	B3050	1	A6884	1	B3050	1	B3050	1
9	SPACER	A6831	2	A6831	2	A6831	2	A6831	2
10	QUICK RELEASE PIN	A4905	1	A4511	1	A4905	1	A4905	1
11	CABLE GUIDE	A6856	1	A6832	1	A6856	1	A6856	1
12	LOAD RATING LABEL	A7604	1	A7605	1	A7604	1	A7604	1

¹ For adjustable boom option, replace boom brace with ratchet jack. Part number C3213 for 571 Series, C3235 for 572 Series.

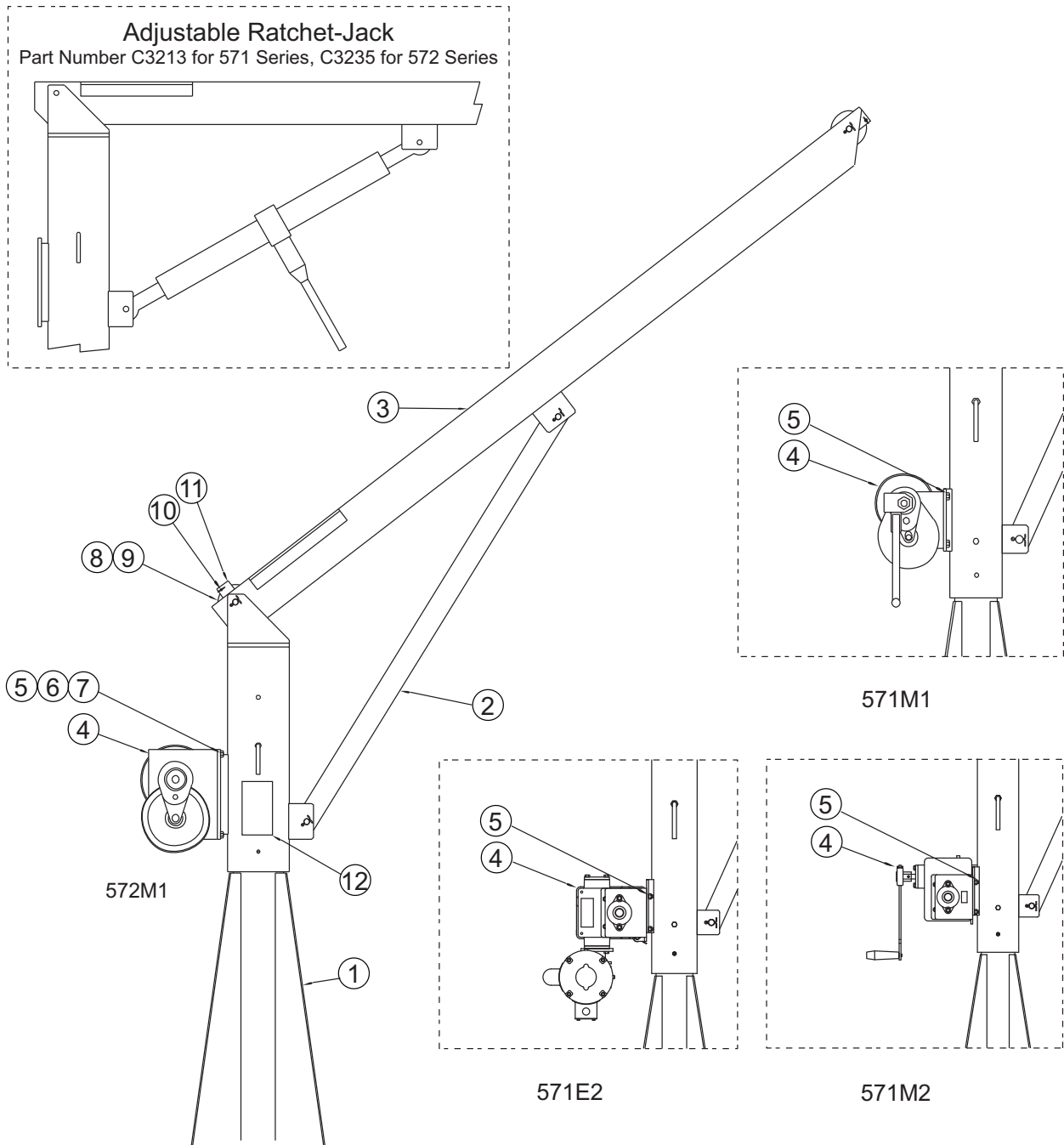

Stationary Davit Crane		571E4		572E3		572E5	
item	description	part number	qty.	part number	qty.	part number	qty.
1	MAST SUBASSEMBLY	C3212	1	C3193	1	C3193	1
2 ¹	BOOM BRACE	B1533	1	B1498	1	B1498	1
3	BOOM SUBASSEMBLY	B3257	1	C3196	1	C3196	1
4	ELECTRIC POWER WINCH	4777-K	1	4771-K	1	4WS3M6-K	1
5	CAPSCREW HEXHD	—	—	—	—	A3164	4
6	FLAT WASHER	—	—	—	—	A2932	8
7	HEX NUT NYLK	—	—	—	—	A2897	4
12	MOUNTING PLATE ASSEMBLY	C3114	1	C3114	1	—	—
12a	MOUNTING PLATE	C3111	1	C3111	1	—	—
12b	CAPSCREW HEXHD	A2975	4	A2975	4	—	—
12c	WASHER HELSPRLK	A2926	4	A2926	4	—	—
12d	CAPSCREW HEXHD	A5042	6	A5042	6	—	—
12e	HEX NUT NYLK	A2927	6	A2927	6	—	—
12f	FLAT WASHER SAE	A2924	6	A2924	6	—	—
13	LOAD RATING LABEL	A7604	1	A7606	1	A7607	1

¹ For adjustable boom option, replace boom brace with ratchet jack. Part number C3213 for 571 Series, C3235 for 572 Series.

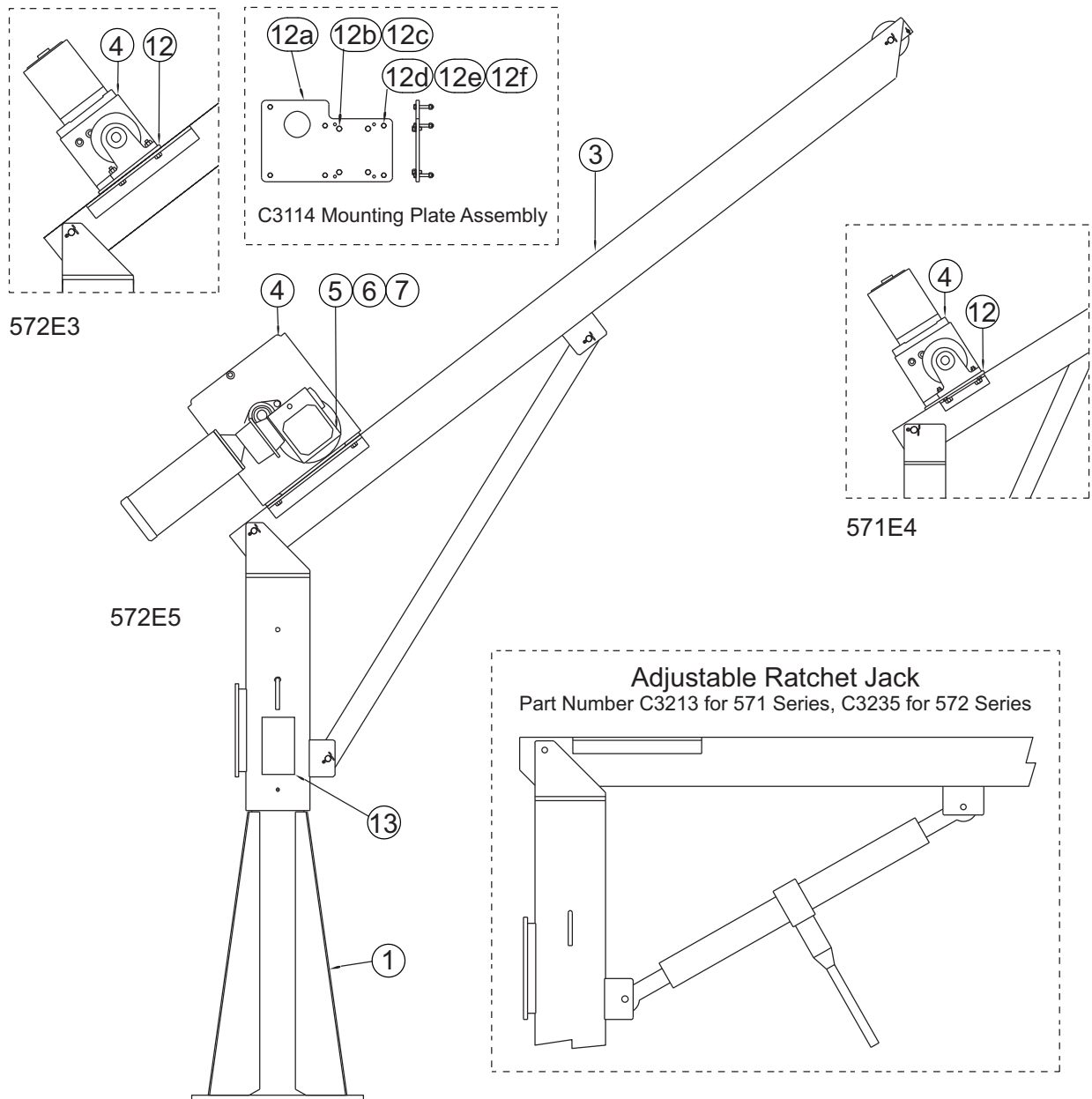

Stationary Mast Subassembly		C3212		C3193	
item	description	part number	qty.	part number	qty.
1	MAST WELDMENT	D1077	1	D1115	1
2	OUTSIDE MAST WELDMENT	C1256	1	C3192	1
3	CRANE LOCK	A1903	1	A1903	1
4	ZERK	A3196	2	A3196	2
5	LARGE ROLLER	A2073	48	A2088	50
6	CAPSCREW HEXHD	A2922	1	A3112	1
7	HEX JAM NUT	A3231	1	A3195	1
8	BRACE PIN	A2072	1	A2093	1
9	COTTER PIN	A3155	4	A3155	4
10	ZERK DRIVE	A3197	1	A3197	1
11	BOOM PIN	A2071	1	A2089	1
12	TAPERED ROLLER BEARING CONE	A2759	1	A2761	1
13	HANDLE	B3292	1	B3292	1
14	CAPSCREW HEXHD	A3472	1	A3472	1
15	HEX NUT	A3235	1	A3235	1
16	THERN LOGO	A2178	1	A2179	1
17	WARNING LABEL	A1961	1	A1961	1
18	NAME PLATE SST	A1976	1	A1976	1
19	LOAD RATING LABEL - RIGHT	A6912	1	A6918	1
20	LOAD RATING LABEL - LEFT	A6914	1	A6919	1

Mast Subassembly
C3212 for 571
C3193 for 572

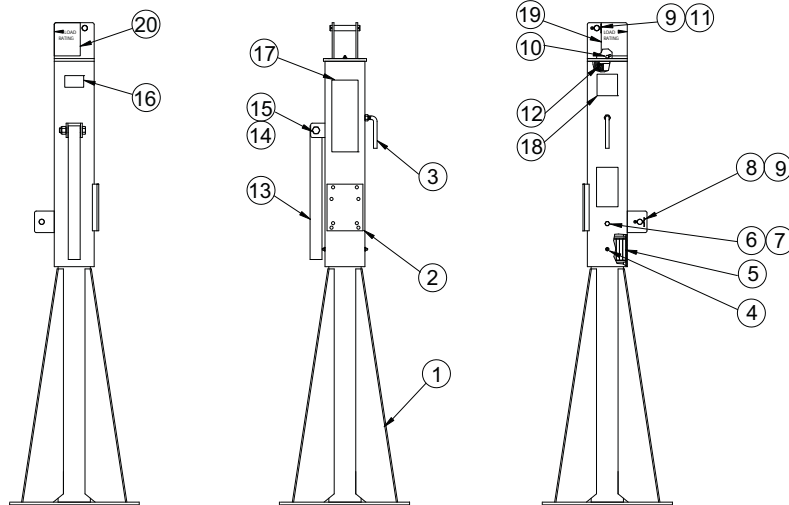

Stationary Boom Subassembly		B3257		C3196	
item	description	part number	qty.	part number	qty.
1	BOOM WELDMENT	B3256	1	C3195	1
2	SHEAVE ASSEMBLY	B3050	1	A6884	1
3	CABLE GUIDE	A6856	1	A6832	1
4	QUICK RELEASE PIN	A4905	1	A4511	1
5	SPACER	A6831	2	A6831	2
6	SHEAVE PIN	A2070	1	A2092	1
7	COTTER PIN	A3155	4	A3155	4
8	BRACE PIN	A2072	1	A2093	1
9	LOAD RATING LABEL LEFT	A6915	1	A6920	1
10	LOAD RATING LABEL RIGHT	A6913	1	A6921	1

Boom Subassembly
B3257 for 571
C3196 for 572

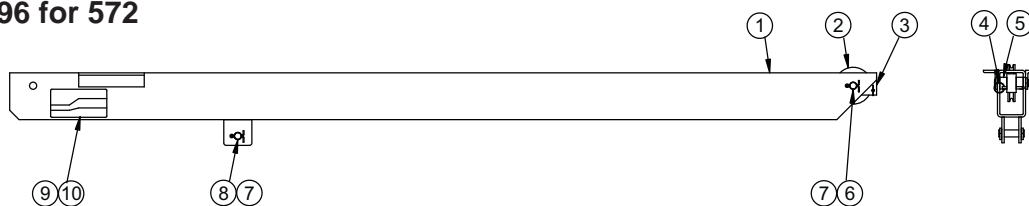

571 Series Performance Characteristics³

wire rope dia.	wire rope length	load rating for 571M1, 571M2 and 572E2				load rating for 571E4 ¹				lift below floor level (min – max) ²
		position A	position B	position C	position D	position A	position B	position C	position D	
1/4 in	28 ft	1200 lb	1350 lb	1500 lb	1500 lb	1200 lb	1350 lb	1500 lb	1500 lb	4 – 9 ft
1/4 in	36 ft	1200 lb	1350 lb	1500 lb	1500 lb	1200 lb	1350 lb	1500 lb	1500 lb	12 – 17 ft
1/4 in	45 ft	1200 lb	1350 lb	1400 lb	1400 lb	1200 lb	1350 lb	1500 lb	1500 lb	21 – 26 ft
1/4 in	60 ft	1200 lb	1300 lb	1300 lb	1300 lb	1200 lb	1350 lb	1400 lb	1400 lb	36 – 41 ft
1/4 in	75 ft	-	-	-	-	1200 lb	1300 lb	1300 lb	1300 lb	51 – 56 ft

¹ Add 2 ft to lift below floor level for Model 571E4.
² Lift below floor level varies depending on boom position and winch configuration. For longer lifts contact factory.
³ Performance Characteristics are for standard products referred to in this manual. Non-standard products may vary from the original design. Contact Thern, Inc. for this information.

572 Series Performance Characteristics³

wire rope dia.	wire rope length	load rating for 572M1 and 572E5 ¹				load rating for 572E3 ¹				lift below floor level (min – max) ²
		position A	position B	position C	position D	position A	position B	position C	position D	
5/16 in	28 ft	1700 lb	2000 lb	2200 lb	2200 lb	1700 lb	1700 lb	1700 lb	1700 lb	-1 – 5 ft
5/16 in	36 ft	1700 lb	2000 lb	2200 lb	2200 lb	1700 lb	1700 lb	1700 lb	1700 lb	7 – 13 ft
5/16 in	45 ft	1700 lb	2000 lb	2200 lb	2200 lb	1500 lb	1500 lb	1500 lb	1500 lb	16 – 22 ft
5/16 in	60 ft	1700 lb	2000 lb	2200 lb	2200 lb	1300 lb	1300 lb	1300 lb	1300 lb	31 – 37 ft
5/16 in	75 ft	1700 lb	2000 lb	2200 lb	2200 lb	1300 lb	1300 lb	1300 lb	1300 lb	46 – 52 ft

¹ Add 3 ft to lift below floor level for Model 572E3 and 572E5.
² Lift below floor level varies depending on boom position and winch configuration. For longer lifts contact factory.
³ Performance Characteristics are for standard products referred to in this manual. Non-standard products may vary from the original design. Contact Thern, Inc. for this information.

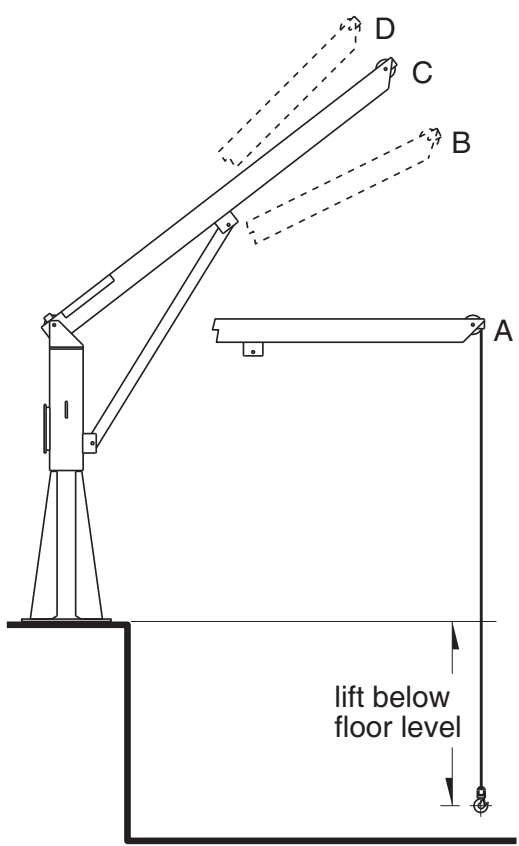

Positions A, B and D require separate order of ratchet jack.

